

SILNIKI NA ŁAPACH - IM B3

56 ÷ 180

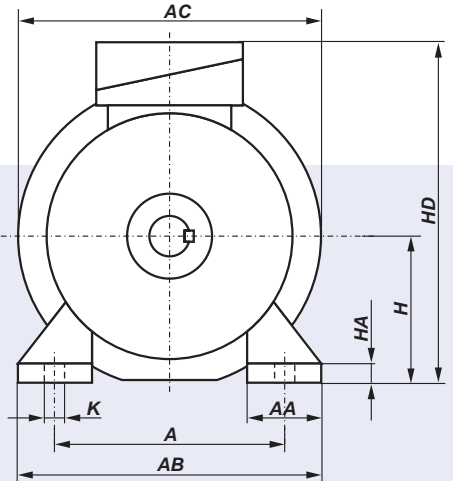

200 ÷ 315

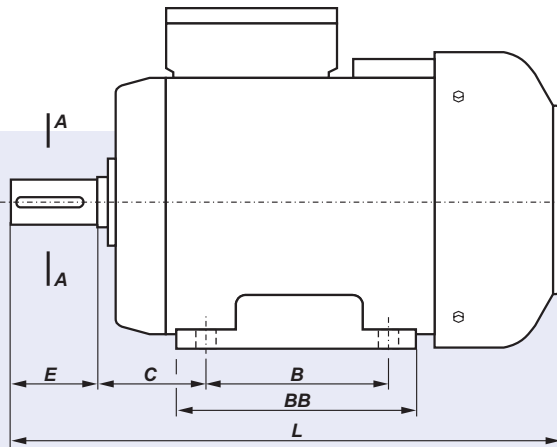
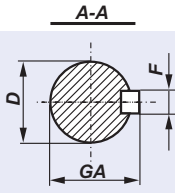
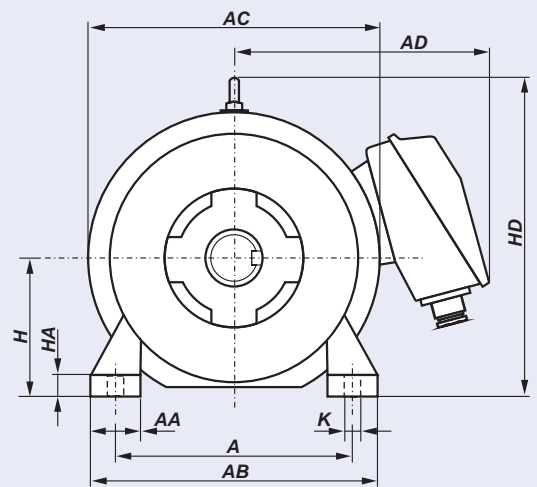
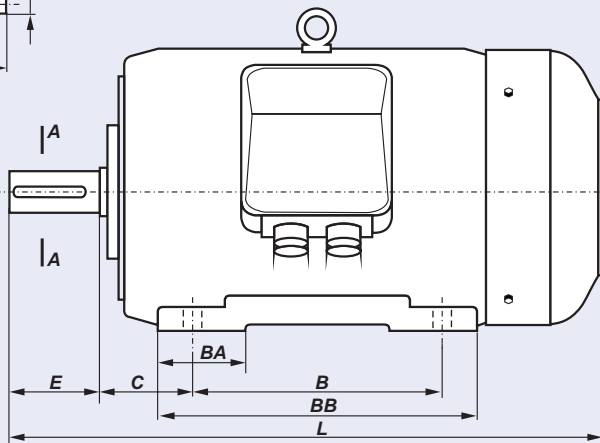
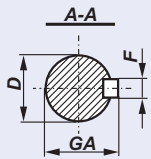

Typ silnika	A	B	C	D	E	F	GA	H	HA	K	AA	AB	AC	AD	BA	BB	HD	L
STg 56X-2+4C	90	71	36	9j6	20	3h9	10,2	56	7	5,8	30	110	117	-	-	92	154	204
STg 63X-2+6C	100	80	40	11j6	23	4h9	12,5	63	8,5	7	36	124	126	-	-	106	165	228
Sh 71X-2+8C	112	90	40	14j6	30	5h9	16	71	8	7	45	142	141	-	-	116	182	263
Sh 80X-2+8C	125	100	50	19j6	40	6h9	21,5	80	9	10	55	160	150	-	-	130	200	306
Sh 80X-2+8D	125	100	50	19j6	40	6h9	21,5	80	9	10	55	160	150	-	-	130	200	318
PSh 90L-2+4	140	125	56	24j6	50	8h9	27	90	10	10	50	170	185	-	-	153	220	354
PSh 90L-6	140	125	56	24j6	50	8h9	27	90	10	10	50	170	185	-	-	153	220	330
PSg 100L-2+6	160	140	63	28j6	60	8h9	31	100	14	12	45	200	206	-	-	172	240	376
PSg 100L-4	160	140	63	28j6	60	8h9	31	100	14	12	45	200	206	-	-	172	240	411
PSg 112M-2+6	190	140	70	28j6	60	8h9	31	112	14	12	54	230	245	-	-	174	276	384
PSg 112M-2A,2B,4A	190	140	70	28j6	60	8h9	31	112	14	12	54	230	245	-	-	174	276	411
PSg 132S-2	216	140	89	38k6	80	10h9	41	132	16	12	56	278	274	-	-	182	310	531
PSg 132M-2+6,2A,4A	216	178	89	38k6	80	10h9	41	132	16	12	56	278	274	-	-	220	310	531
Sg 160L2+8z	254	254	108	42k6	110	12h9	45	160	20	15	60	300	327	125	-	292	366	649
PSg 180L-2+4	279	279	121	48k6	110	14h9	51,5	180	26	15	70	350	360	-	-	320	408	756
Sg 180M2z	279	241	121	48m6	110	14h9	51,5	180	24	15	75	330	365	125	-	320	400	675
Sg 180L4+8z	279	279	121	48m6	110	14h9	51,5	180	24	15	75	330	365	125	-	320	400	675
Sg 200L2+8z	318	305	133	55m6	110	16h9	59	200	32	19	80	400	450	355	100	380	485	810
Sg 225M2z	356	311	149	55m6	110	16h9	59	225	34	19	85	445	505	375	110	380	535	855
Sg 225M4+8z	356	311	149	60m6	140	18h9	64	225	34	19	85	445	505	375	110	380	535	885
Sg 250M2z	406	349	168	60m6	140	18h9	64	250	36	24	90	495	540	415	120	420	590	980
Sg 250M4+8z	406	349	168	65m6	140	18h9	69	250	36	24	90	495	540	415	120	420	590	980
Sg 280M2z	457	419	190	65m6	140	18h9	69	280	40	24	100	560	620	450	165	520	660	1040
Sg 280M4+8z	457	419	190	75m6	140	20h9	79,5	280	40	24	100	560	620	450	165	520	660	1040
Sg 315M6+8Bz	508	457	216	80m6	170	22h9	85	315	46	28	105	610	620	450	190	560	695	1210

WYMIARY MONTAŻOWE I GABARYTOWE

**SILNIKI KOŁNIERZOWE NA ŁAPACH - IM B35**  
**SILNIKI KONIERZOWE - IM B5**

56 ÷ 180

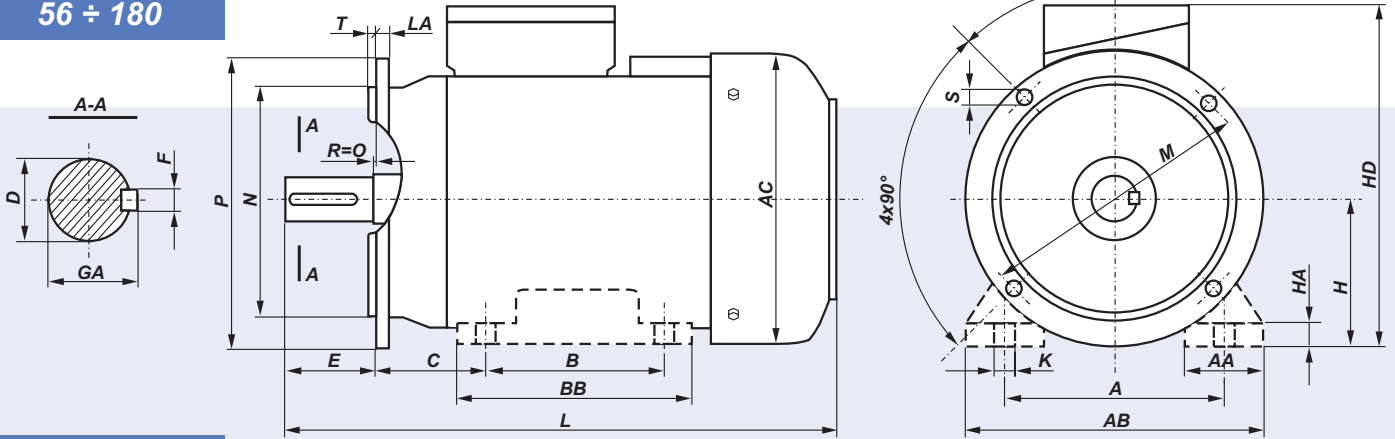

200 ÷ 315

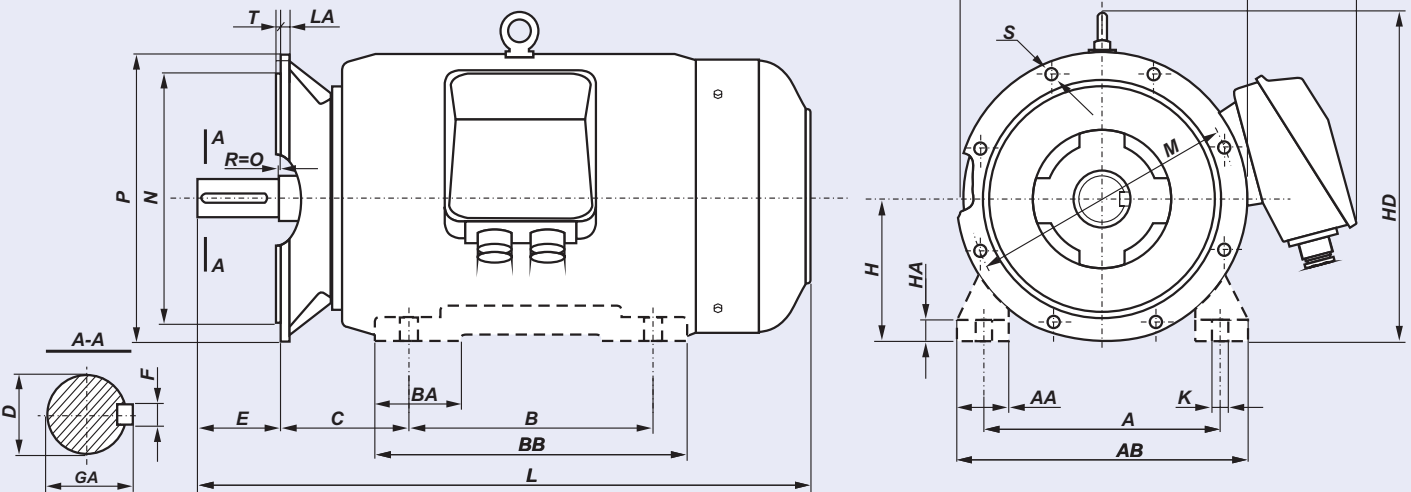

Typ silnika	A	B	C	D	E	F	GA	H	HA	K	AA	AB	AC	AD/AD <sup>1</sup>	BA	BB	HD	L	LA	M	N	P	T	S	Φ	otwory
STLg 56X-2+4C	90	71	36	9j6	20	3h9	10,2	56	7	5,8	30	110	117	-	-	92	154	204	8	100	80j6	120	3	7	4	
STLg 63X-2+6C	100	80	40	11j6	23	4h9	12,5	63	8,5	7	36	124	126	-	-	106	165	228	9	115	95j6	140	3	10	4	
SLh 71X-2+8C	112	90	40	14j6	30	5h9	16	71	8	7	45	142	141	-	-	116	182	263	9	130	110j6	160	3,5	10	4	
SLh 80X-2+8C	125	100	50	19j6	40	6h9	21,5	80	9	10	55	160	150	-	-	130	200	306	10	165	130j6	200	3,5	12	4	
SLh 80X-2+8D	125	100	50	19j6	40	6h9	21,5	80	9	10	55	160	150	-	-	130	200	318	10	165	130j6	200	3,5	12	4	
PSLh 90L-2+4	140	125	56	24j6	50	8h9	27	90	10	10	50	170	185	-	-	153	220	354	8	165	130j6	200	3,5	12	4	
PSLh 90L-6	140	125	56	24j6	50	8h9	27	90	10	10	50	170	185	-	-	153	220	330	8	165	130j6	200	3,5	12	4	
PSLg 100L-2+6	160	140	63	28j6	60	8h9	31	100	14	12	45	200	206	-	-	172	240	376	11	215	180j6	250	4	15	4	
PSLg 100L-4	160	140	63	28j6	60	8h9	31	100	14	12	45	200	206	-	-	172	240	411	11	215	180j6	250	4	15	4	
PSLg 112M-2+6	190	140	70	28j6	60	8h9	31	112	14	12	54	230	245	-	-	174	276	384	12	215	180j6	250	4	15	4	
PSLg 112M-2A,2B,4A	190	140	70	28j6	60	8h9	31	112	14	12	54	230	245	-	-	174	276	411	12	215	180j6	250	4	15	4	
PSLg 132S-2	216	140	89	38k6	80	10h9	41	132	16	12	56	278	274	-	-	182	310	531	12	265	230j6	300	4	15	4	
PSLg 132M-2+6,2A,4A	216	178	89	38k6	80	10h9	41	132	16	12	56	278	274	-	-	220	310	531	12	265	230j6	300	4	15	4	
SLg 160L2+8z	254	254	108	42k6	110	12h9	45	160	20	15	60	300	327	125/206	-	292	366	649	13	300	250j6	350	5	18	4	
PSLg 180L-2+4	279	279	121	48k6	110	14h9	51,5	180	26	15	70	350	360	-	-	320	408	756	13	300	250j6	350	5	19	4	
SLg 180M2z	279	241	121	48m6	110	14h9	51,5	180	24	15	75	330	365	125/220	-	320	400	675	13	300	250j6	350	5	18	4	
SLg 180L4+8z	279	279	121	48m6	110	14h9	51,5	180	24	15	75	330	365	125/220	-	320	400	675	13	300	250j6	350	5	18	4	
SLg 200 L2+8z	318	305	133	55m6	110	16h9	59	200	32	19	80	400	450	355/340	100	380	485	810	16,5	350	300j6	400	5	18	4	
SLg 225 M2z	356	311	149	55m6	110	16h9	59	225	34	19	85	445	505	375/360	110	380	535	855	18	400	350j6	450	5	18	8	
SLg 225 M4+8z	356	311	149	60m6	140	18h9	64	225	34	19	85	445	505	375/360	110	380	535	885	18	400	350j6	450	5	18	8	
SLg 250 M2z	406	349	168	60m6	140	18h9	64	250	36	24	90	495	540	415/405	120	420	590	980	19	500	450j6	550	5	18	8	
SLg 250 M4+8z	406	349	168	65m6	140	18h9	69	250	36	24	90	495	540	415/405	120	420	590	980	19	500	450j6	550	5	18	8	
SLg 280 M2z	457	419	190	65m6	140	18h9	69	280	40	24	100	560	620	450/440	165	520	660	1040	20	500	450j6	550	5	18	8	
SLg 280 M4+8z	457	419	190	75m6	140	20h9	79,5	280	40	24	100	560	620	450/440	165	520	660	1040	20	500	450j6	550	5	18	8	
SLg 315 M6+8z	508	457	216	80m6	170	22h9	85	315	46	28	105	610	620	450/440	190	560	695	1210	22	600	550js6	660	6	22	8	

<sup>1</sup> - AD - wymiar dla wykonania kołnierzego na łapach  
 AD1 - wymiar dla wykonania kołnierzego

WYMIARY MONTAŻOWE I GABARYTOWE

**FSILNIKI KOŁNIERZOWE NA ŁAPACH - IM B34**  
**SILNIKI KOŁNIERZOWE - IM B14**

56 ÷ 80

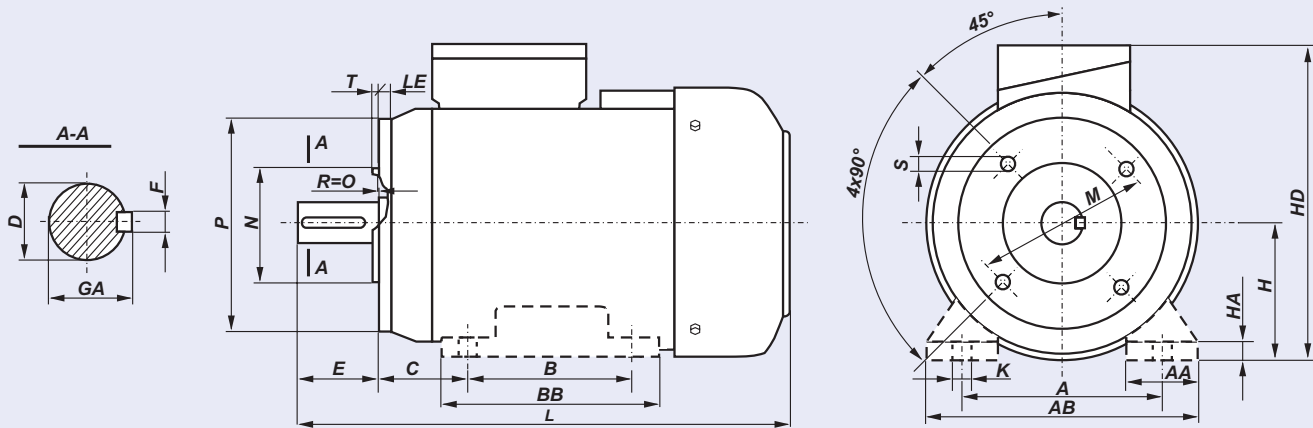

Typ silnika	Kołnierz	A	AA	B	C	D	E	F	GA	H	HA	K	M	N	P	S	LE	T	HD	L
STLg 56X-2÷4C1	B14/C1	90	30	71	36	9j6	20	3h9	10,2	56	7	8	85	70j6	105	M6	15	2,5	154	204
STLg 56X-2÷4C2	B14/C2	90	30	71	36	9j6	20	3h9	10,2	56	7	8	65	50j6	80	M5	12,5	2,5	154	204
STLg 63X-2÷6C1	B14/C1	100	36	80	40	11j6	23	4h9	12,5	63	8,5	10	100	80j6	120	M6	14	3	165	228
STLg 63X-2÷6C2	B14/C2	100	36	80	40	11j6	23	4h9	12,5	63	8,5	10	75	60j6	90	M5	9,5	2,5	165	228
SLh 71X-2÷8C1	B14/C1	112	45	90	45	14j6	30	5h9	16	71	8	10	115	95j6	140	M8	14	3	182	263
SLh 71X-2÷8C2	B14/C2	112	45	90	45	14j6	30	5h9	16	71	8	10	85	70j6	105	M6	12	2,5	182	263
SLh 80X-2÷8C1	B14/C1	125	55	100	50	19j6	40	6h9	21,5	80	9	10	130	110j6	160	M8	14	3,5	200	306
SLh 80X-2÷8C2	B14/C2	125	55	100	50	19j6	40	6h9	21,5	80	9	10	100	80j6	120	M6	12	3	200	306
SLh 80X-2÷8D1	B14/C1	125	55	100	50	19j6	40	6h9	21,5	80	9	10	130	110j6	160	M8	14	3,5	200	318
SLh 80X-2÷8D2	B14/C2	125	55	100	50	19j6	40	6h9	21,5	80	9	10	100	80j6	120	M6	12	3	200	318

WYMIARY MONTAŻOWE I GABARYTOWE